

SINGAPORE CHINESE GIRLS' SCHOOL
SECOND SEMESTRAL ASSESSMENT 2007

NAME: _____ ()

DATE: _____

CLASS: PRIMARY 5 (S) / C / G / SE / P

SCIENCE
BOOKLET A

30 questions

60 marks

Total time for Booklets A & B: 1 h 45 min

DO NOT OPEN THIS BOOKLET UNTIL YOU ARE TOLD TO DO SO.

FOLLOW ALL INSTRUCTIONS CAREFULLY.

Part 1 (60 marks)

For each question from 1 to 30, four options are given. One of them is the correct answer. Make your choice (1, 2, 3 or 4). Shade the correct oval (1, 2, 3 or 4) on the Optical Answer Sheet.

Study the table below carefully and answer Questions 1 and 2.

Group A	Group B	Group C
Cobra	Tortoise	Bat
Red snapper	Crab	Platypus
Iguana	Oyster	Zebra

1. Some animals have been classified into three groups as shown above. Which of the following are suitable headings for the three groups?

	Group A	Group B	Group C
1)	Lay eggs	Give birth	Lay eggs
2)	Live in water	Live on land	Live on land and water
3)	Covered with scales	Covered in feathers	Covered in hair
4)	Covered with scales	Covered in hard shell	Covered in hair

2. What is a similarity between the animals in Group A and B?

- ~~1)~~ Live in water
- ~~2)~~ Live on land
- ~~3)~~ Lay eggs
- ~~4)~~ Breathe through gills

3. Study Life Cycles A and B below carefully.

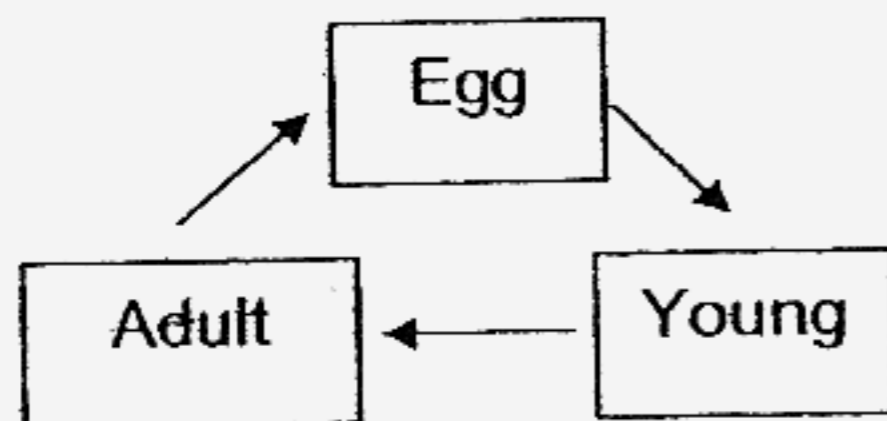

Life Cycle A

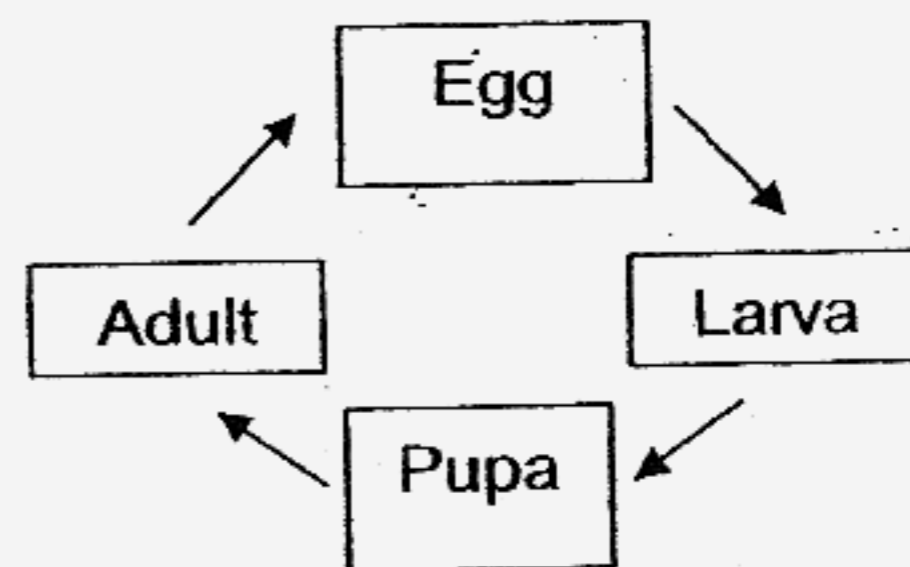

Life Cycle B

Which one of the following pairs of animals has its life cycle shown above?

	Life Cycle A	Life Cycle B
1)	Cow	Grasshopper
2)	Cockroach	Dragonfly
3)	Grasshopper	Guppy
4)	Platypus	Fruit fly

3 stages

4. Jeremy carried out an experiment as shown below. In his experiment, he put two similar seedlings into two similar beakers with the same volume of water. In Set-up A, he used tap water while in Set-up B, he used boiled water. He also put a layer of oil on Set-up B's water surface. He wanted to find out which seedling, the one grown in tap water or the one grown in boiled water, would be taller after five days.

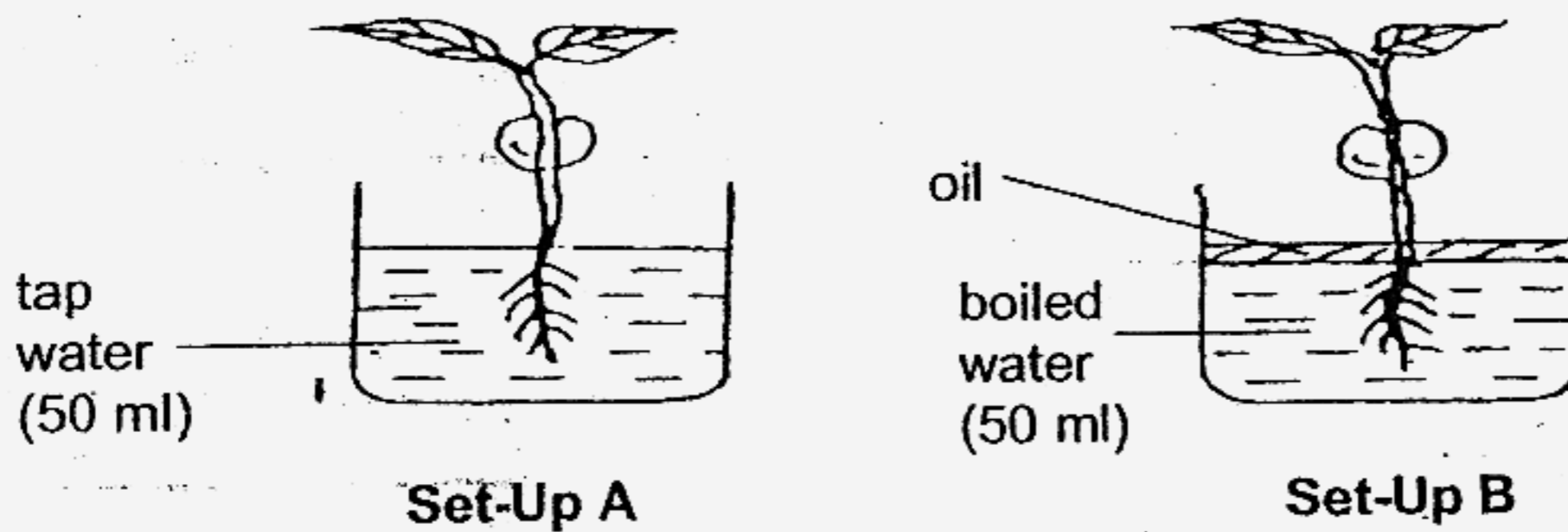

His friend, Karen, concluded that it was an unfair test after making the following observations.

- A: Different types of water were used.
- B: Equal amounts of water were used.
- C: Beaker A did not have a layer of oil.

Which of the above comments supports Karen's conclusion?

- 1) A only
- 2) A and B only
- 3) C only
- 4) A, B and C

5. Jane described an object as slimy, round and blue.
Which of her senses did she use to make this observation?

- A: Sight
- B: Taste
- C: Touch
- D: Smell

- 1) A and B
- 2) A and C
- 3) B and C
- 4) C and D

6. Which of the following **correctly** shows the path food takes in the digestive system?

- 1) Mouth → Stomach → Large intestine → Anus → Small intestine
- 2) Gullet → Small intestine → Stomach → Large intestine → Anus
- 3) Mouth → Gullet → Stomach → Small intestine → Large intestine → Anus
- 4) Mouth → Stomach → Gullet → Small intestine → Large intestine → Anus

7. Tim plotted the graph below after completing several activities. A, B and C record the average pulse rate of each activity.

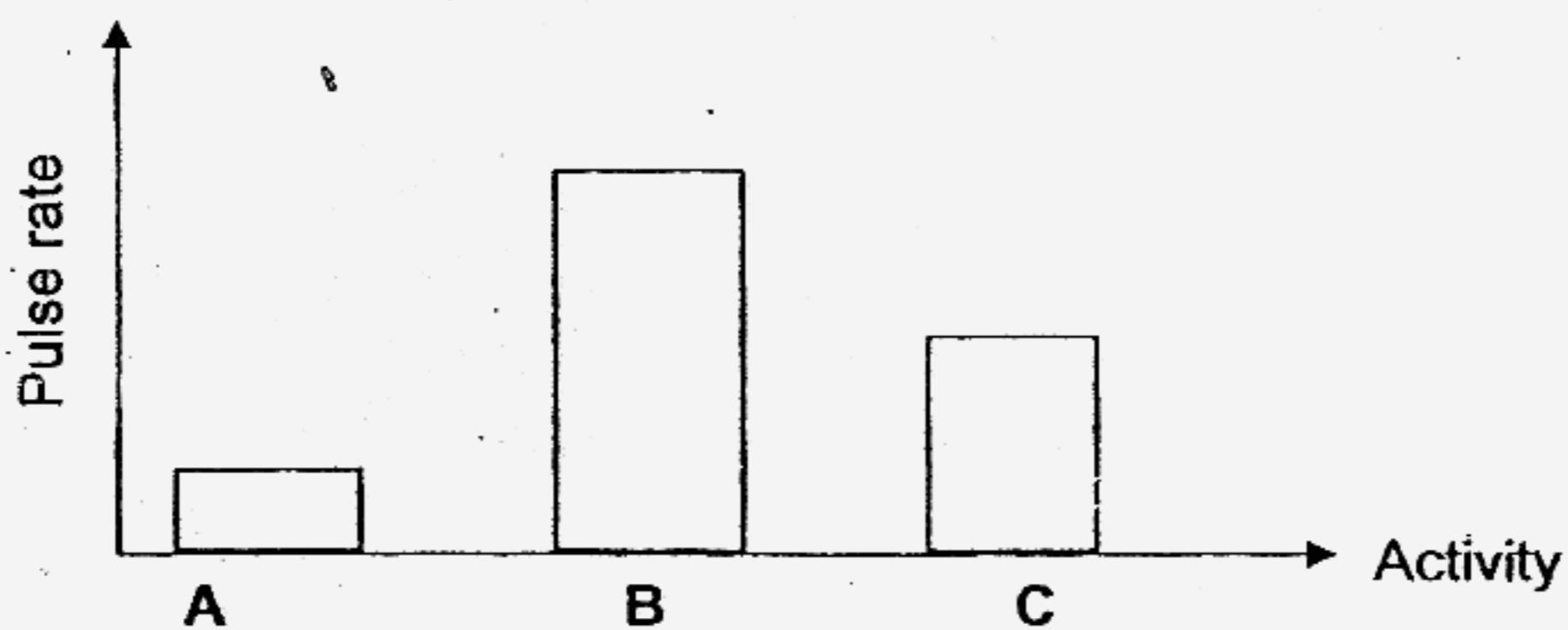

Which of the following activities best describes the pulse rate at each point?

	A	B	C
1)	Running	Reading	Strolling
2)	Swimming	Sleeping	Walking
3)	Reading	Running	Walking
4)	Resting	Strolling	Swimming

Study the classification chart below carefully and answer Questions 8 and 9.

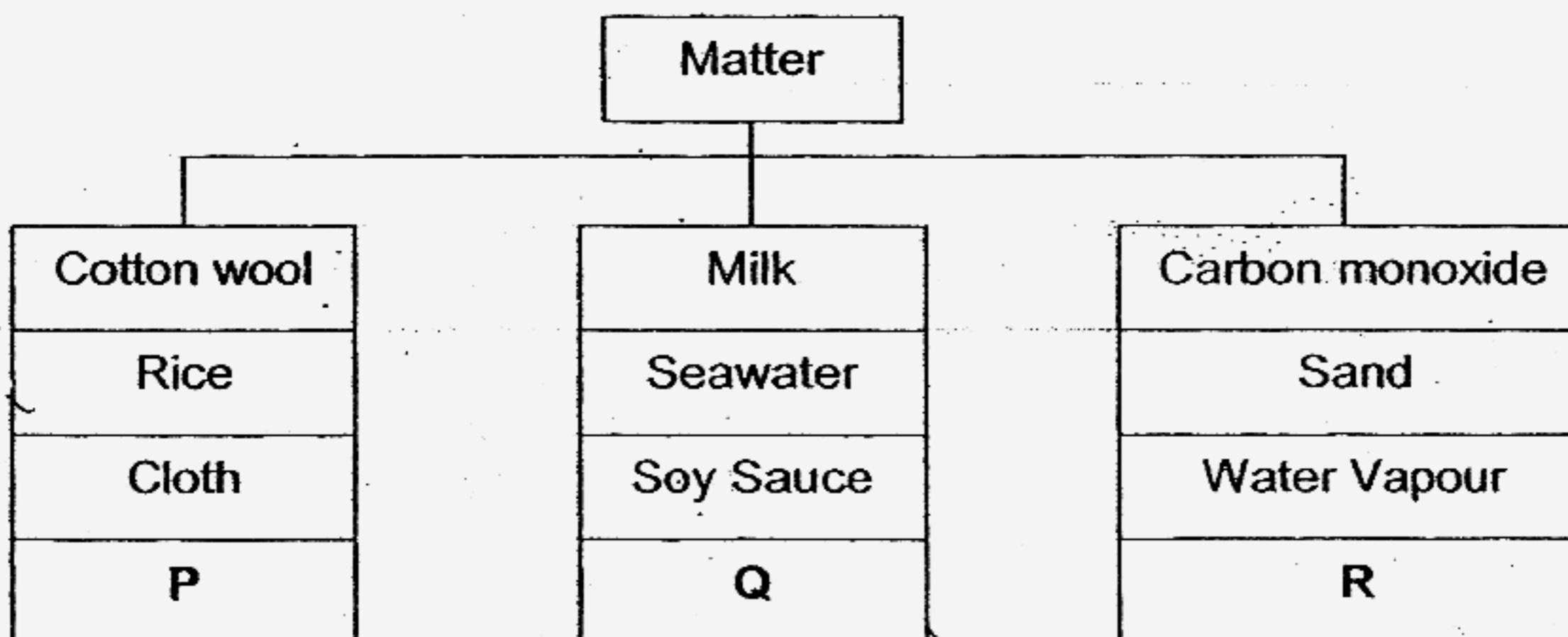

8. _____ has been **wrongly** classified.

- ~~1) Rice~~ ~~3) Seawater~~
~~2) Sand~~ ~~4) Carbon monoxide~~

9. Which of the following items can replace P, Q and R respectively?

	P	Q	R
1)	Soup	Box	Nitrogen
2)	Strawberry	Nitrogen/	Coke
3)	Helium	Basket	Milo
4)	Octopus	Blood	Oxygen

10. Karen shone a torchlight at a basketball with a diameter of 30 cm and a piece of cardboard, 15 cm by 5 cm, as shown below.

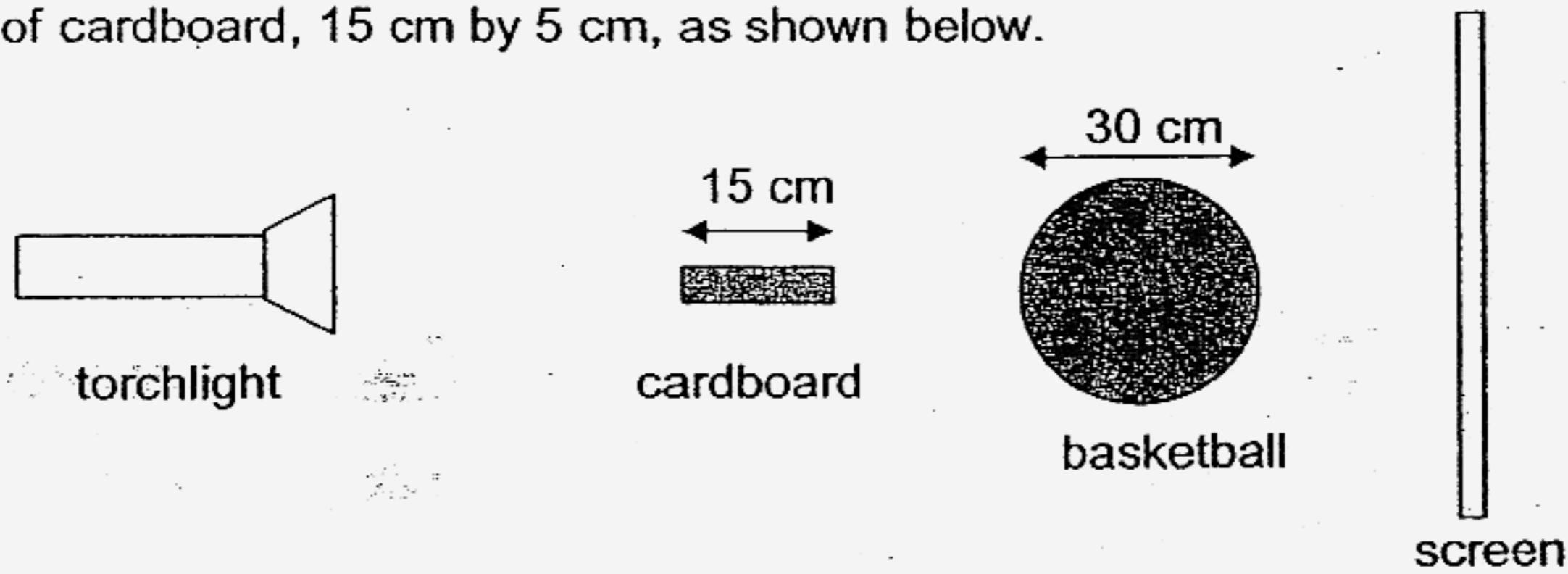

Which one of the following pictures shows the shadow most likely cast by the two objects on the screen?

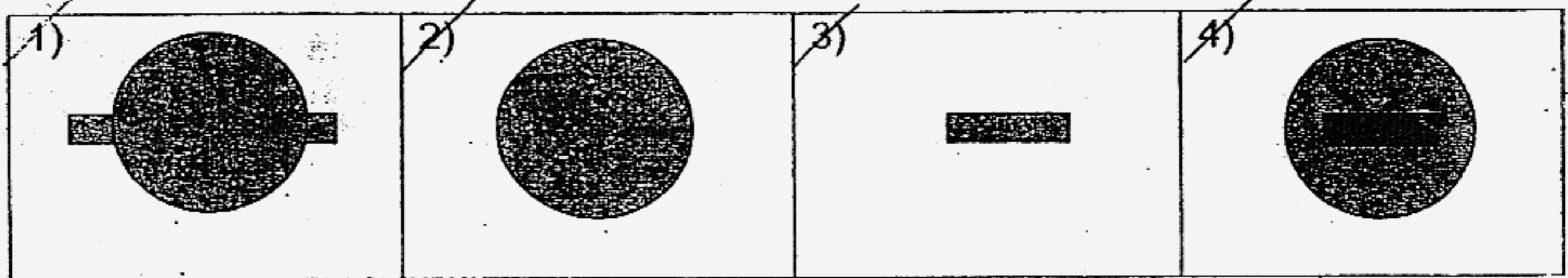

11. The letters A to E in the table below represent objects in space.

	Man-made	Gives out own light	Revolves around the Earth
A	Yes	No	No
B	Yes	Yes	No
C	No	Yes	No
D	Yes	No	Yes
E	No	No	Yes

Which of the letters, A, B, C, D or E, best represents the moon, the satellite and the star?

	The Moon	Telecommunication satellite	The Star
1)	B	D	C
2)	E	B	C
3)	C	A	B
4)	E	D	C

12. Which part of a cell controls the behaviour of the cell?

- 1) Nucleus
- 2) Cell membrane
- 3) Cell wall
- 4) Cytoplasm

13. Cindy, Paula, Kelly and Amelia each received a slide from their teacher to observe with a microscope. They recorded the parts of the cells observed in the following table.

	Parts of cells
Cindy	Cytoplasm, cell membrane
Paula	Cytoplasm, cell wall , nucleus
Amelia	Chloroplasts , cytoplasm, cell membrane
Kelly	Nucleus, cell membrane, cytoplasm

Which pupil(s) could have observed plant cells?

- ~~1) Paula only~~ ~~3) Kelly only~~
~~2) Kelly and Amelia only~~ 4) Paula and Amelia only
14. During fertilisation, D from the E parent fuses with F from the G parent to form a zygote. What are D, E, F and G?

	D	E	F	G
1)	sperm	male	sperm	female
2)	sperm	male	egg	female
3)	egg	male	sperm	female
4)	egg	female	egg	male

15. Which one of the following shows the correct sequence in the reproduction of flowering plants?

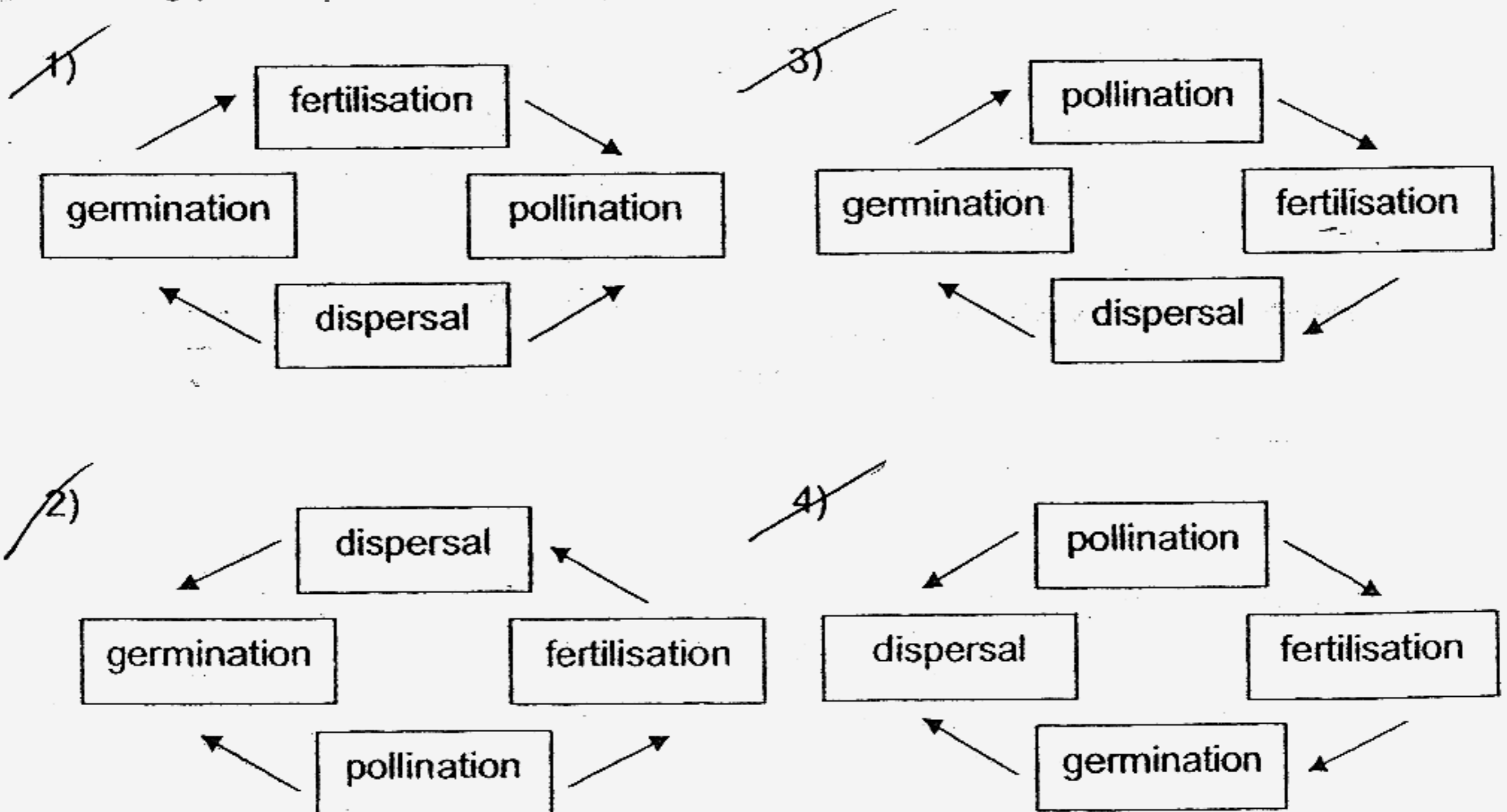

16. Terrence made the following statements about photosynthesis.

- A : It can only take place in the day.
- B : It is the process of making food in plants.
- C : Only plants with chlorophyll can undergo this process.
- D : Glucose and oxygen are released during this process.

Which one of them is **incorrect**?

- ~~1)~~ A
- ~~2)~~ B

- ~~3)~~ C
- ~~4)~~ D

17. Andrew classified some items into two groups as shown below after completing an experiment to test for starch.

Group W	Group X
Potato	Leather
Bread	Grouper
Spaghetti	Mutton
M	N

Which of the following pairs of items can substitute **M** and **N** respectively?

	Group W	Group X
1)	Turnip	Yam
2)	Pearl	Ginger
3)	Shrimp	Highlighter
4)	Paper	Beef

18. Which of the following shows the intakes during the processes photosynthesis and respiration respectively?

	Photosynthesis	Respiration
1)	Glucose	Oxygen
2)	Water	Energy
3)	Carbon dioxide	Glucose
4)	Oxygen	Water

19. Christine set up the apparatus as shown below. She left both set ups in a warm dark place for 15 hours. The limewater in Set-up A turned chalky but the limewater in Set-up B remained unchanged.

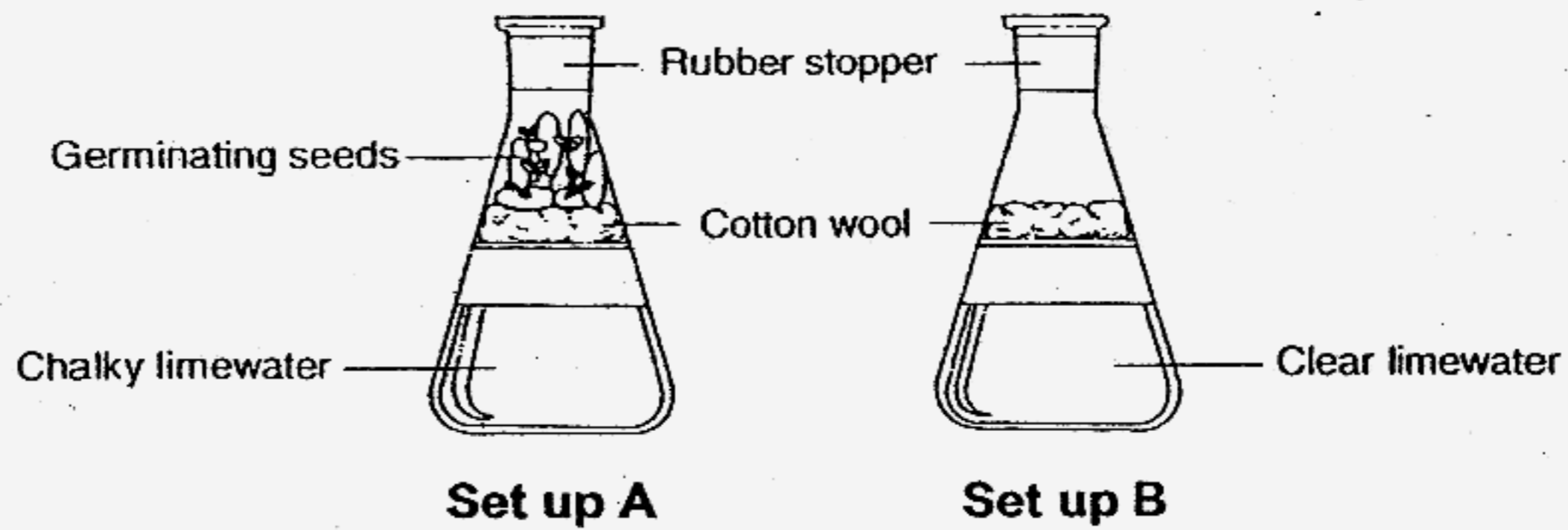

Her aim for the above experiment was to find out if _____.

- 1) germinating seeds respire
 - 2) limewater turns chalky by itself
 - 3) cotton wool turns limewater clear
 - 4) germinating seeds photosynthesise
20. Which one of the following correctly shows how energy is passed?

- 1) Sun → grass → lion
- 2) Sun → rabbit → grass
- 3) Sun → grass → rabbit → lion
- 4) Sun → grass → lion → rabbit

21. The bar graph below shows the number of Organisms ~~W, X, Y and Z~~ living together.

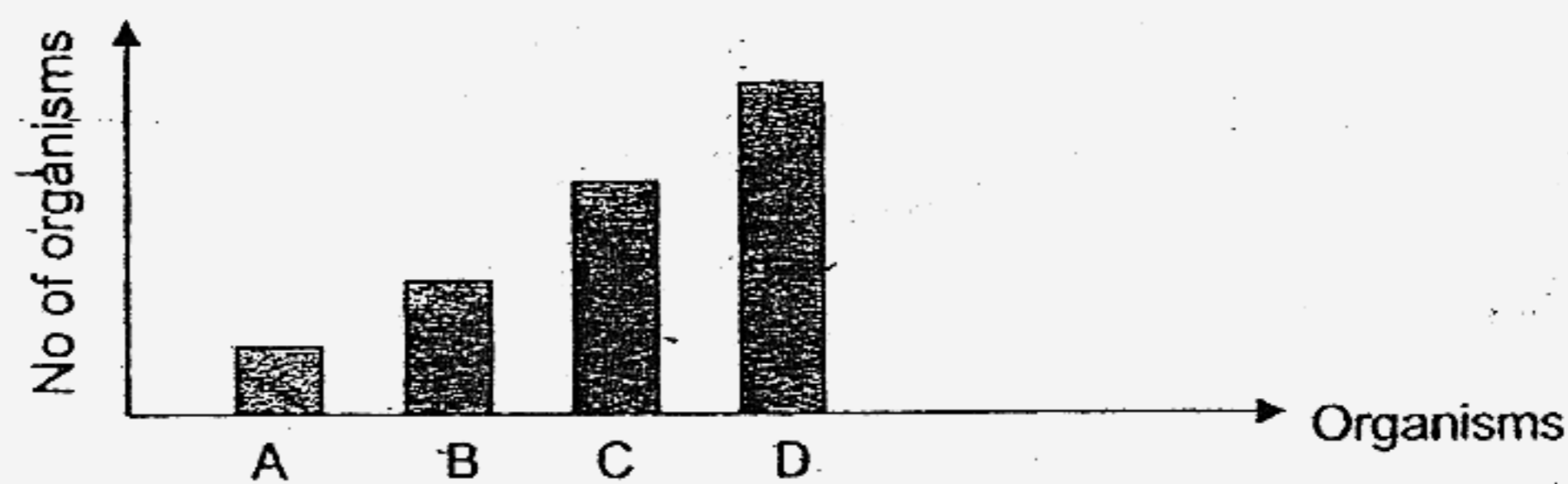

Based on the graph, which one of the following food chains is possible?

- 1) A → C → D → B
- 2) B → D → C → A
- 3) C → A → D → B
- 4) D → C → B → A

22. Which one of the following is **NOT** an effect of a force?

- ~~1)~~ A dented ping pong ball.
- ~~2)~~ A ball rolling after being kicked.
- ~~3)~~ A wind sock fluttering in the wind.
- ~~4)~~ A bar of chocolate melting in the sun.

23. Mohsin and Hambali were playing marbles. Both marbles were moving when Hambali's marble hit Mohsin's marble.

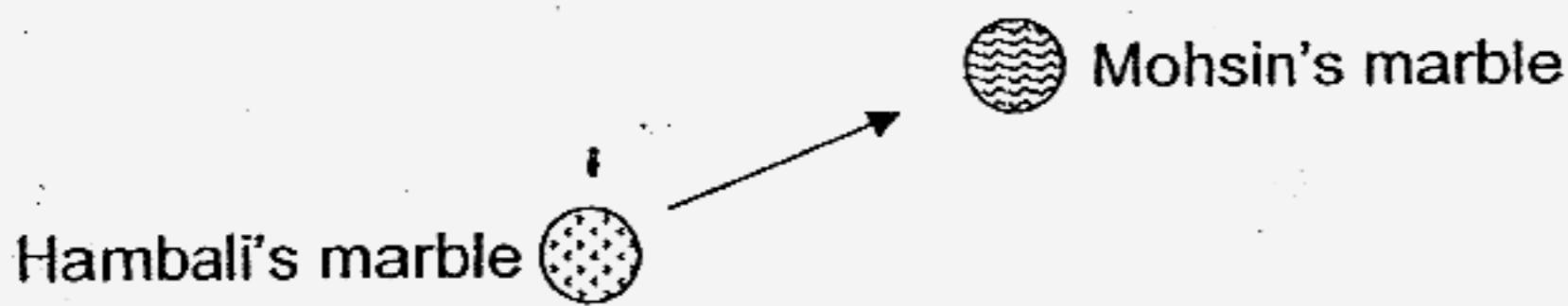

As a result, Mohsin's marble _____.

- ~~1)~~ became dented and moved slightly
- ~~2)~~ began to move in a different direction
- ~~3)~~ gained speed and started to spin by itself
- ~~4)~~ moved in the same direction as Hambali's marble

24. Warren wrote down the following statements after learning about simple machines. Which one of them is **incorrect**?

- ~~1)~~ All types of simple machines enable us to do work with less effort.
- ~~2)~~ Fixed pulleys only change the direction of the force but effort is the same.
- ~~3)~~ In the case of the spanner, the effort moves a greater distance than the load.
- ~~4)~~ The bicycle and the telpher line are made up of a combination of simple machines.

25. In the pulley system shown below, the load moves up by 14 cm. What is the distance moved by the effort?

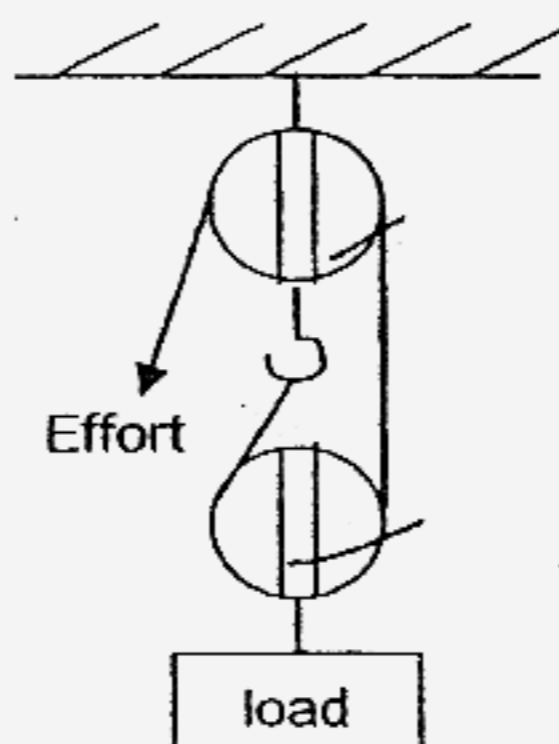

- ~~1)~~ 3.5 cm
- ~~2)~~ 7 cm
- ~~3)~~ 14 cm
- ~~4)~~ 28 cm

26. Study the diagrams below carefully.

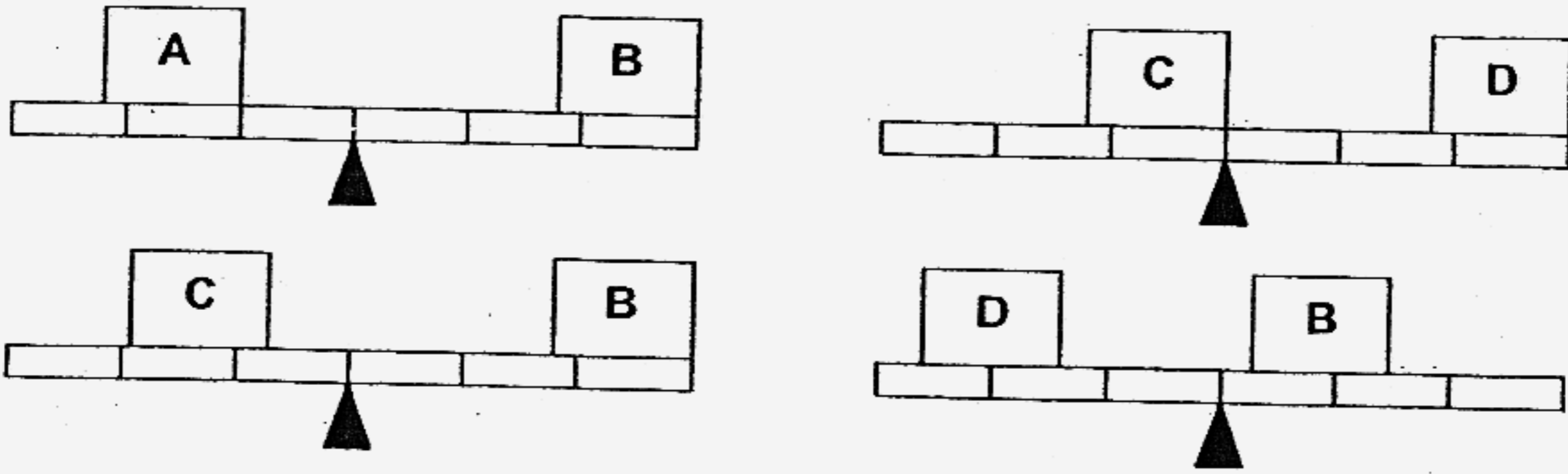

Arrange the above objects (A, B, C and D) from the heaviest to the lightest.

- ~~1) A, C, B, D~~
~~2) B, A, C, D~~
~~3) C, A, B, D~~
~~4) D, B, A, C~~

27. Timothy wanted to load a box onto his pick-up lorry. He learnt in one of his Science lessons that an inclined plane can help him do this work with less effort. Which of the following diagrams below requires the least effort to push the box up the inclined plane onto the lorry?

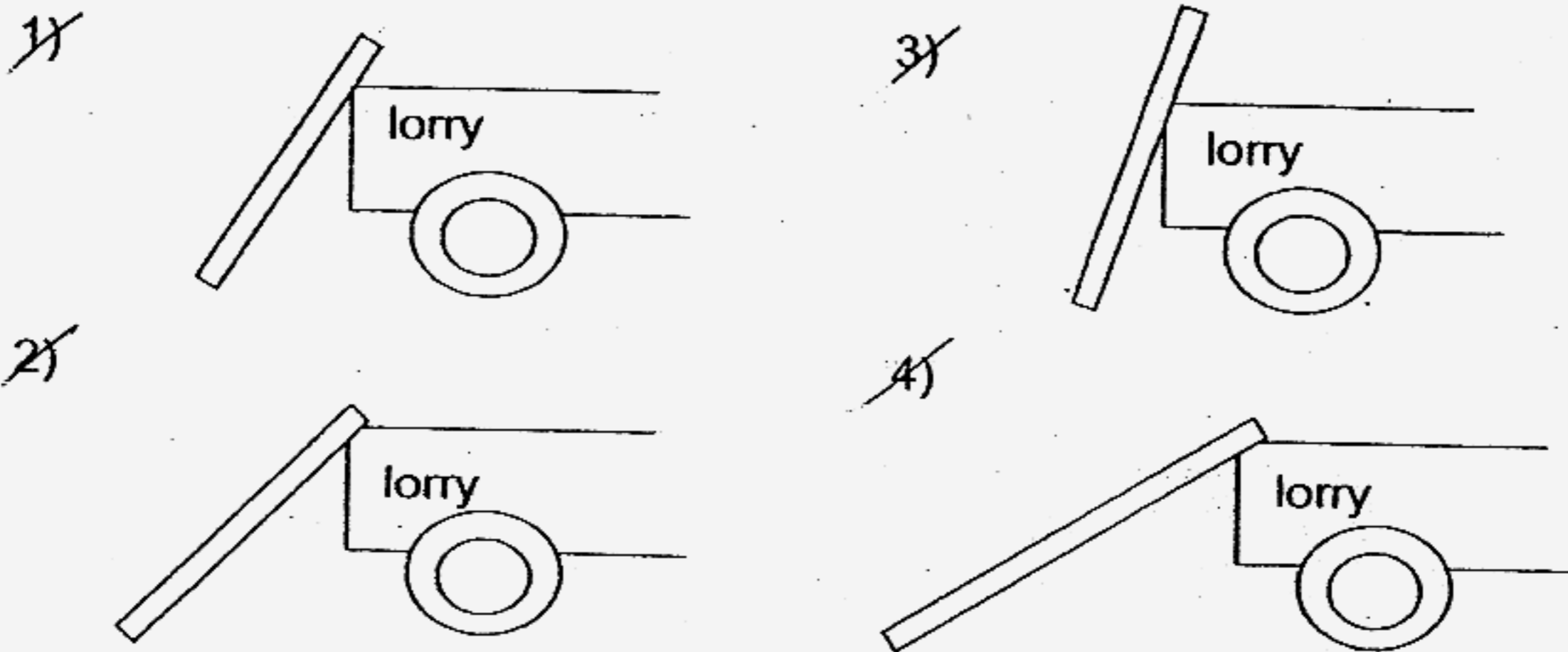

28. Study the flowchart below.

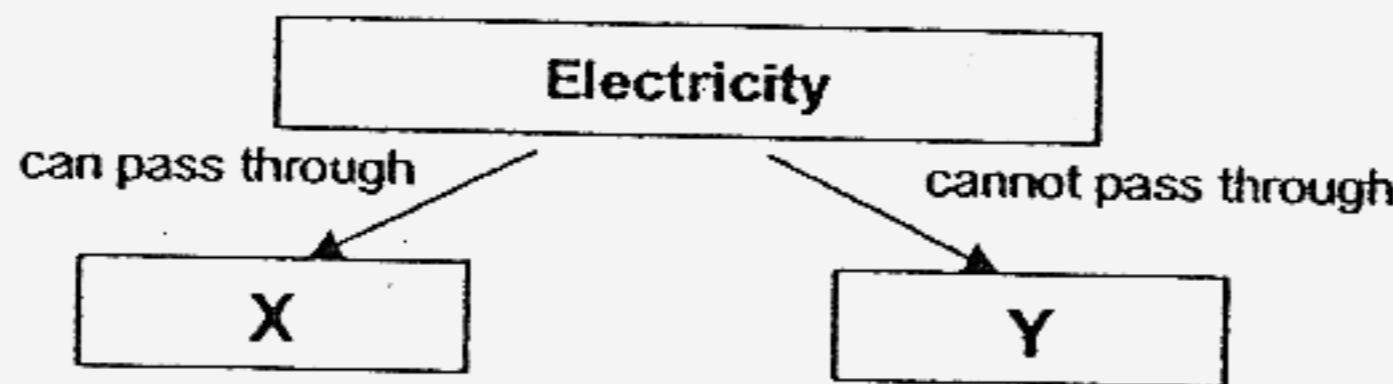

Which of the following can be X and Y?

	X	Y
1)	steel, clay	tin, glass
2)	aluminium, silver	paper, plastic
3)	crayon, cloth	copper, iron
4)	water, gold	air, bronze

29. Benjamin tested a circuit board and recorded the results in the table below.

Clips tested	Did the bulb light up?
A and B	Yes
A and C	No
A and D	Yes
B and C	No
B and D	Yes
C and D	No

Which of the following diagrams show the possible connections of the clips by wires?

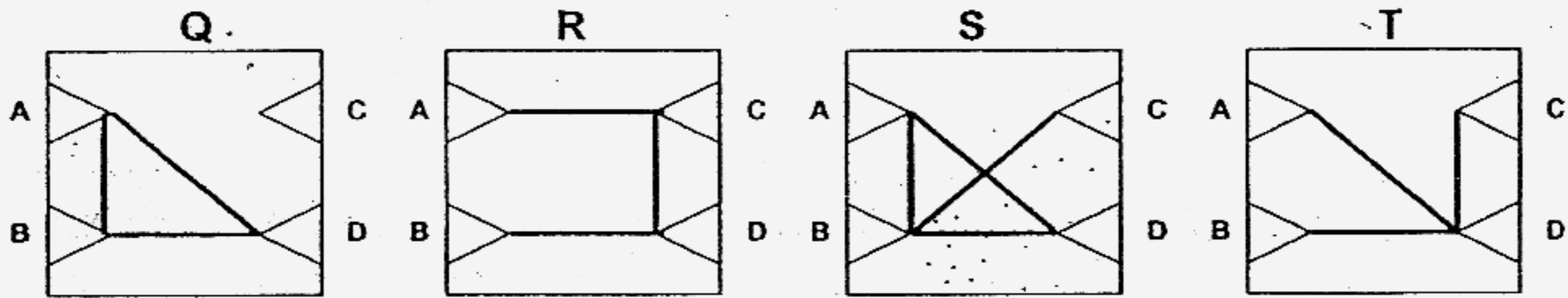

- 1) Q only
 2) Q, S and T only
 3) Q and S only
 4) Q, R, S and T

30. The graph below shows the electrical usage in the Tan household from January to June.

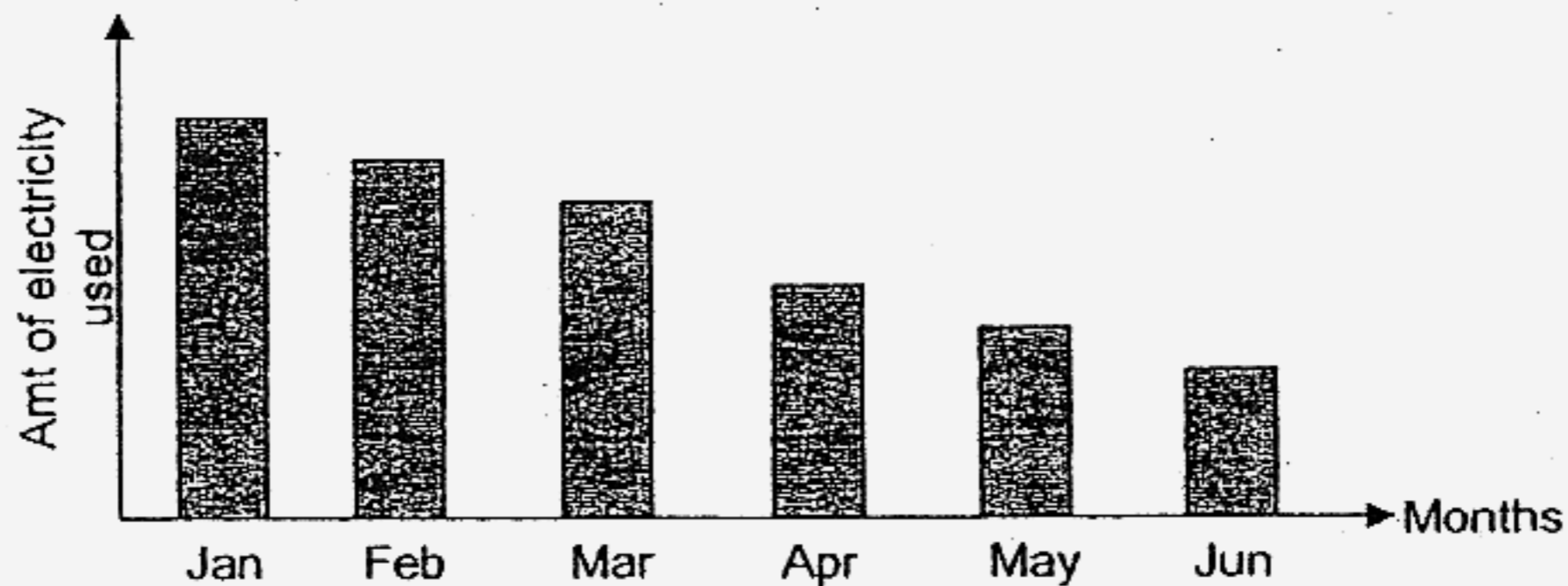

Which of the following activities could have contributed to the decreasing trend of electrical usage from February to June in the Tan household?

- A: Replace air-conditioners with fans
 B: Take hot showers at all times
 C: Use energy-saving light bulbs
 D: Turn on air-conditioners all day
 E: Switch off lights when not in use

- 1) A, B and E only
 2) A, C and E only
 3) B, D and E only
 4) C, D and E only

SINGAPORE CHINESE GIRLS' SCHOOL
SECOND SEMESTRAL ASSESSMENT 2007

NAME: _____ ()

DATE: _____

CLASS: PRIMARY 5 (SY) / C / G / SE / P

	Marks Obtained	Total Marks
Booklet A		60
Booklet B		40
Total		100

Parent's Signature

SCIENCE

BOOKLET B

16 questions

40 marks

Total time for Booklets A & B: 1 h 45 min

DO NOT OPEN THIS BOOKLET UNTIL YOU ARE TOLD TO DO SO.

FOLLOW ALL INSTRUCTIONS CAREFULLY.

Part 2 (40 marks)

Answer all the following questions.

31. The table below shows the properties of three materials.

Materials	Durable	Transparent	Float on water	Conductor of electricity
X	✓			✓
Y	✓	✓	✓	
Z	✓		✓	

a) Describe the properties of material X. (1m)

b) Janie wants to make a toy boat for her younger brother to play while he takes his bath. Which material(s) is/are suitable for this purpose? Explain your answer. (2m)

32. Catherine was given three similar handkerchiefs that were equally wet. She carried out an experiment and tabulated the results in the table below.

Handkerchief	No of folds	Place	Time taken for water to evaporate (min)
A	0	Under the sun	15
B	1	Under the sun	45
C	2	Under the sun	120

a) What was the aim of her experiment? (1m)

b) Did Catherine carry out a fair experiment? Explain your answer. (1m)

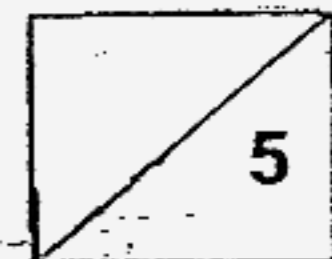

33. The electric iron uses a bimetallic thermostat to regulate its temperature while it is being used, keeping it at the desired temperature of 90°C. The strip, which is made up of two types of metals fastened together, 'senses' changes in temperature and works as an electric contact breaker in an electric heating circuit. Below is a simple setup of such a circuit in an electric iron.

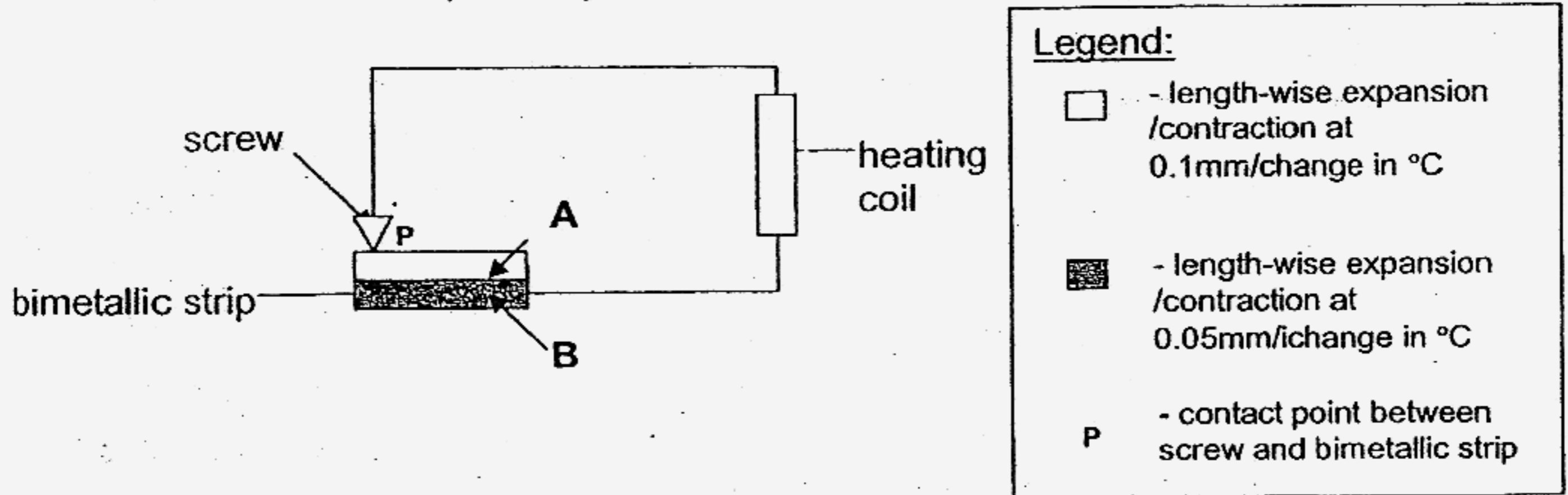

Thermostat shown above is at 24°C. The bimetallic strip touches the screw to allow electricity to flow and heat up the heating coil.

a) Tick below the picture/s showing the correct way the bimetallic strip has reacted to the change in temperature. (2m)

Temperature	91°C	95°C
Bimetallic strip		
Is strip correctly shown?		
Temperature	7°C	48°C
Bimetallic strip		
Is strip correctly shown?		

b) Name another home appliance that requires the use of a bimetallic thermostat to help regulate its temperature. (1m)

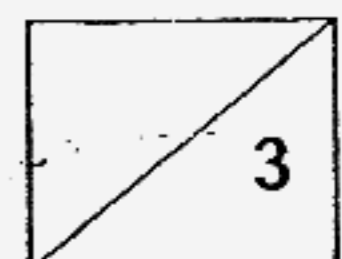

34. The diagram below shows the Sun and the Earth.

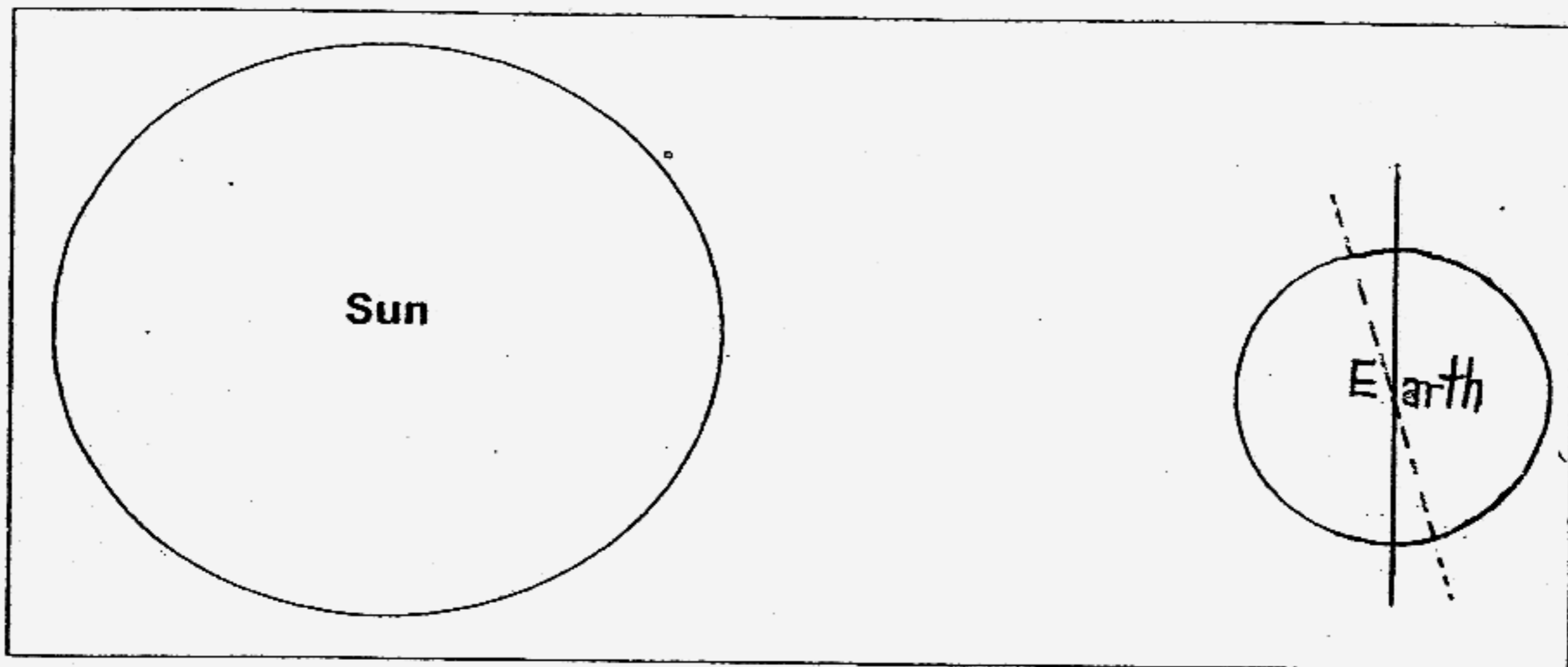

- Shade fully the part of the Earth that is experiencing night. (½ m)
- The dotted line represents the _____ on which the Earth rotates from _____ to _____. (1 ½ m)

35. Hanlin wanted to obtain pure water from seawater. He tried to do that by using the setup shown below.

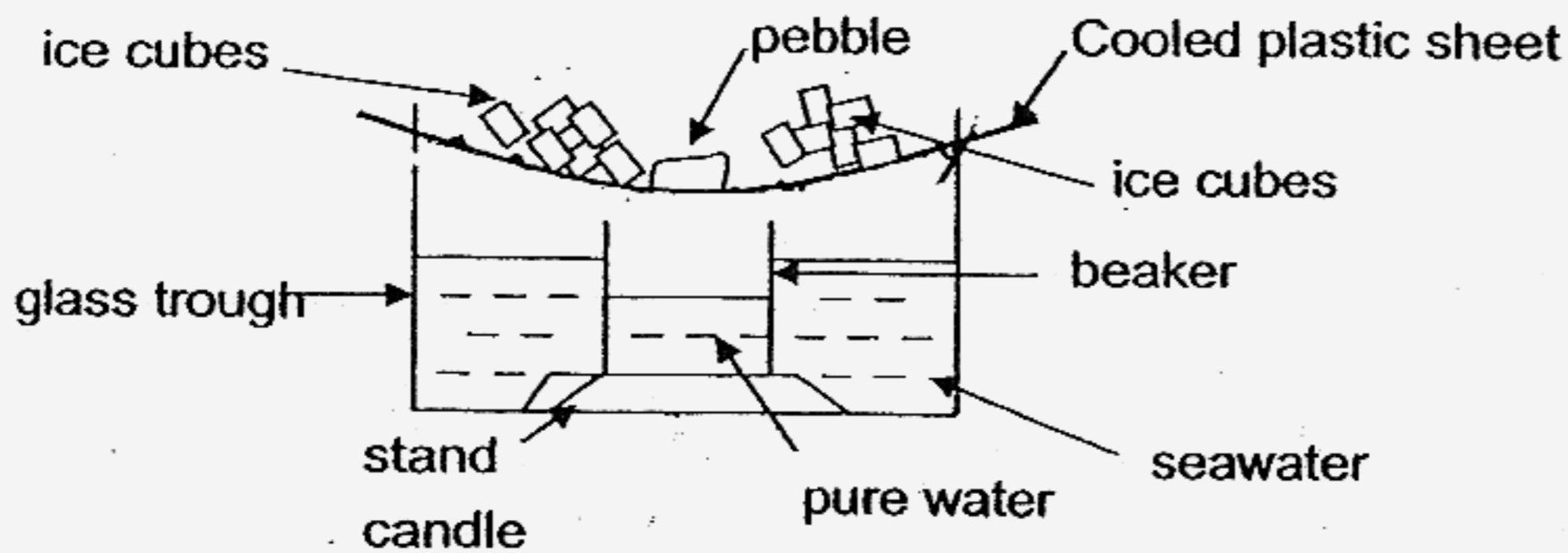

a) Draw on the diagram what the campers would observe on the cooled plastic sheet after a few minutes. (1m)

b) What is the purpose of the pebble? (1m)

c) What can be done to the set-up to speed up the collection of pure water? (1m)

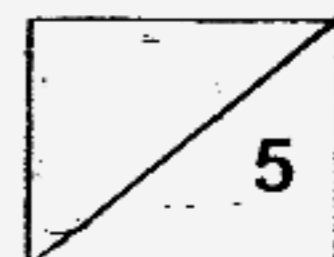

36. The graph below shows Kelvin's height from birth until he was 40 years old.

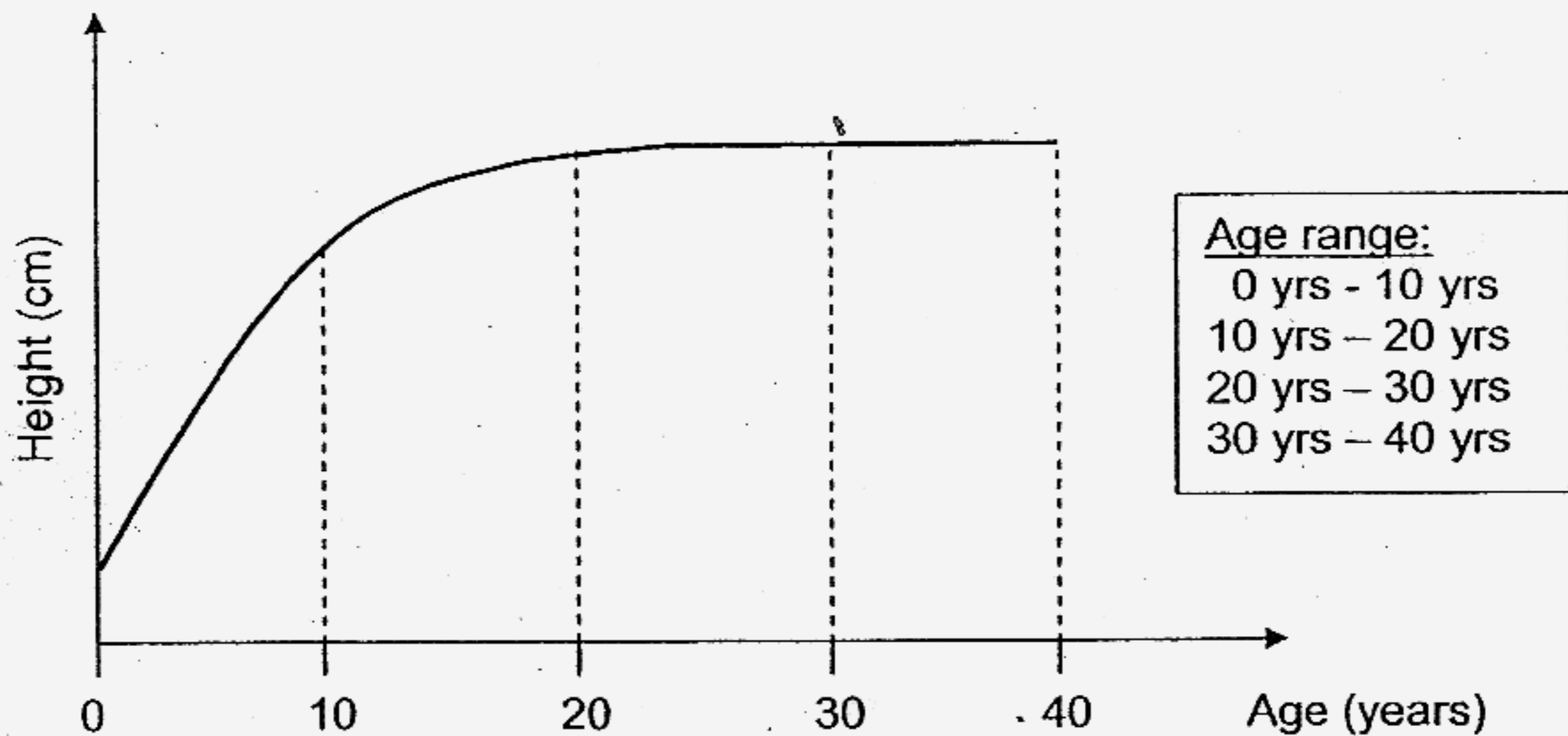

- a) At what age range did Kelvin's height start to remain the same? (1m)
-
- b) Cell division was responsible for the increase in Kelvin's height. Name another function of cell division. (1m)
-

37. The diagram below shows Fatimah's family tree.

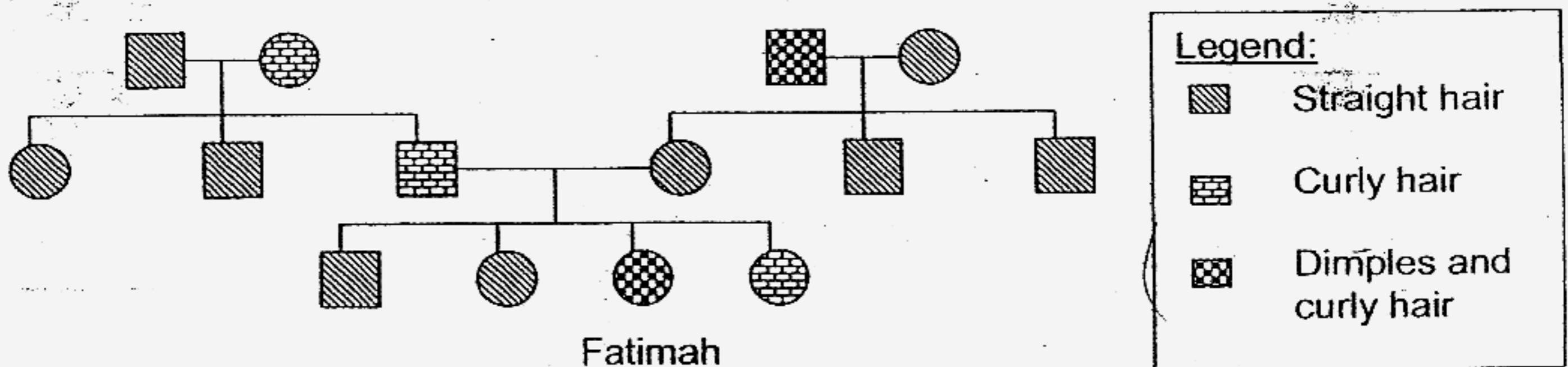

- a) Which characteristic trait has skipped a generation? (1m)
-
- b) How many people in the family have curly hair? (1m)
-

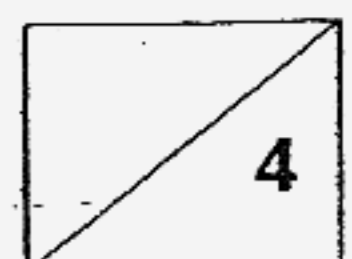

38. Study the flowchart carefully.

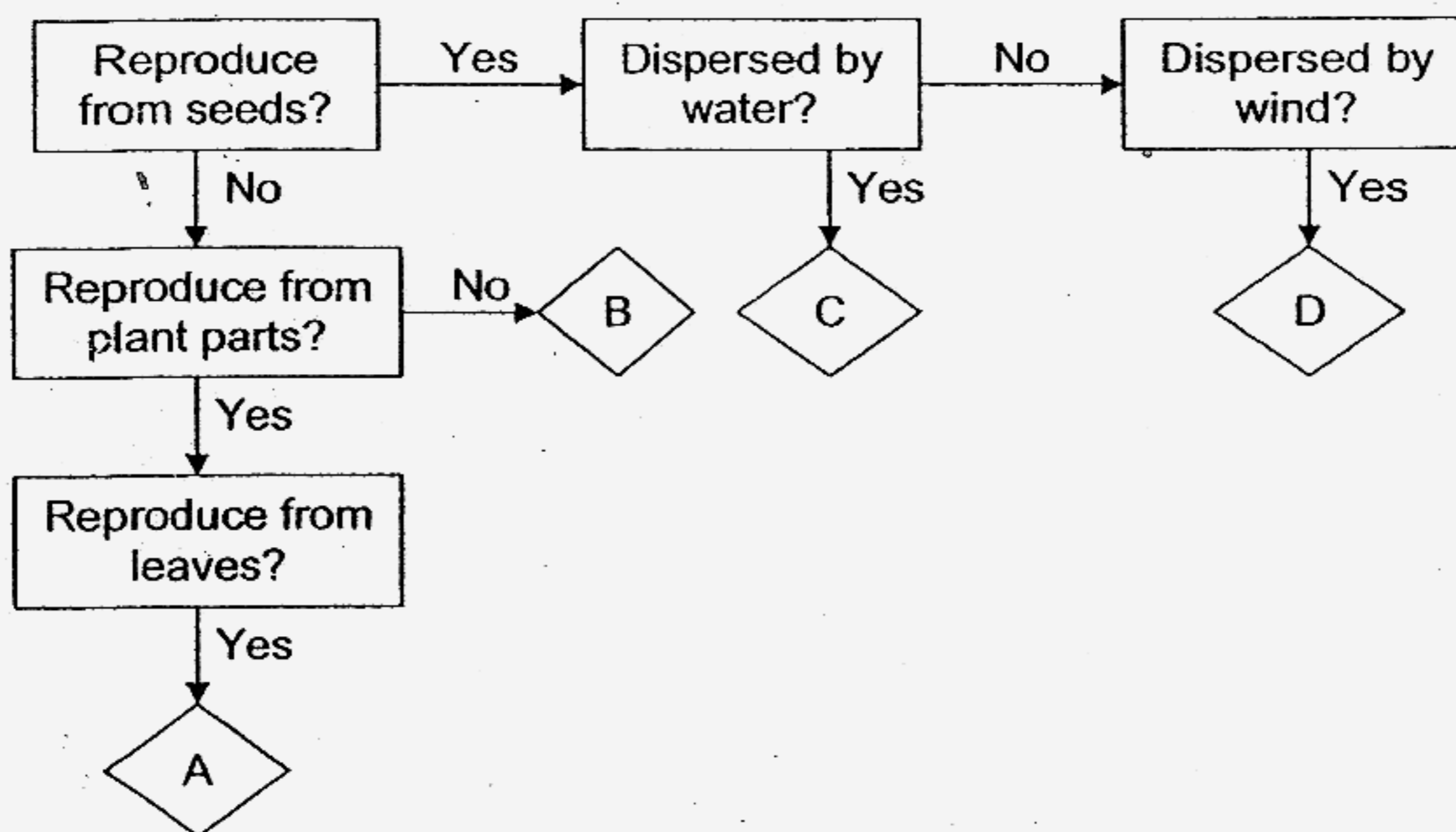

a) Give an example for B. (1m)

b) Name the two characteristics D has to enable it to be dispersed by wind. (1m)

39. Sammy conducted an experiment and tabulated the results below.

Plants	Amt of carbon dioxide taken (mu)	Amt of carbon dioxide produced (mu)
A	430	415
B	500	400
C	459	413

Note:
mu – milli units

a) What is the trend that is reflected by the above data? (1m)

b) Name the process(es) the plants are undergoing? (1m)

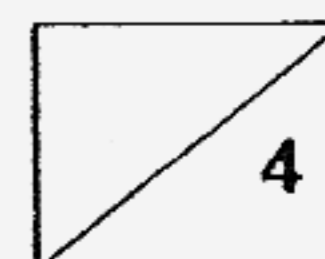

40. Study the chart below carefully.

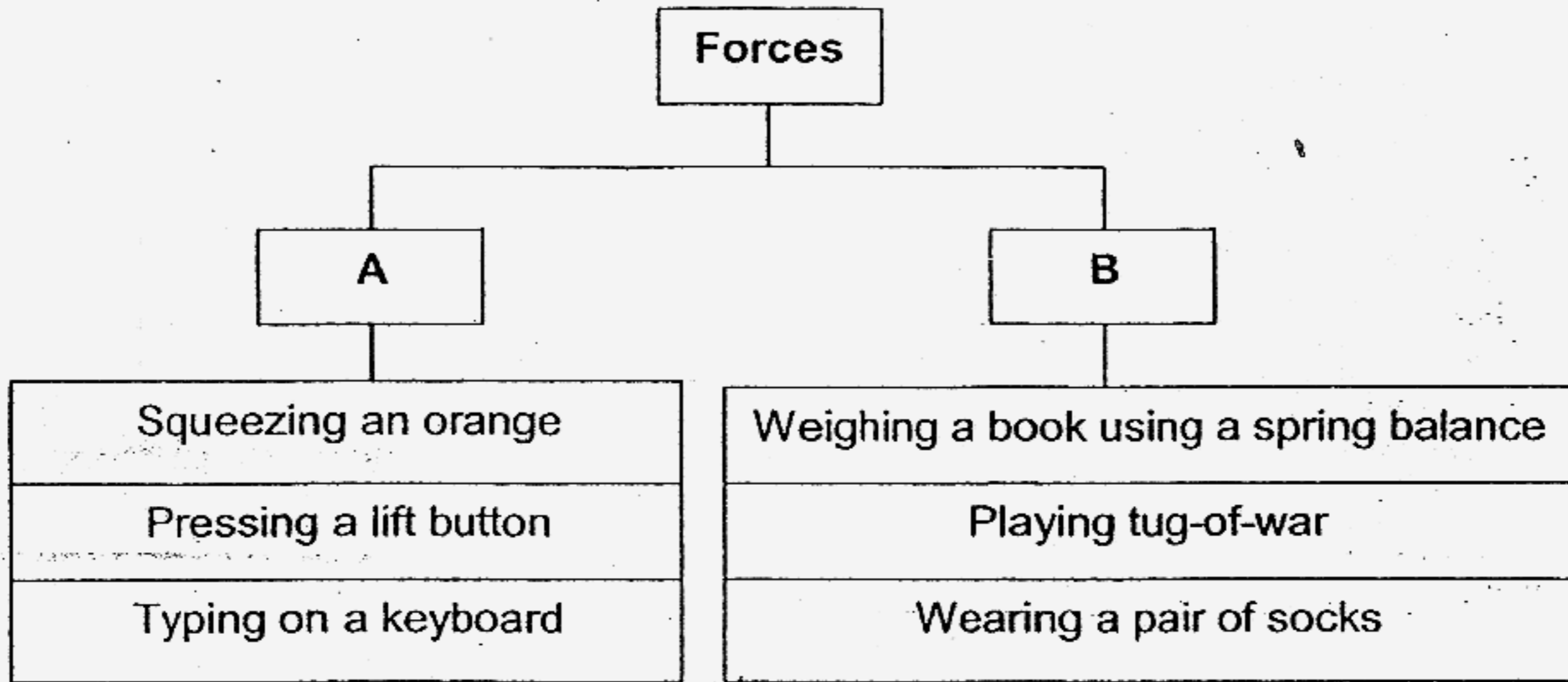

a) Write down the headings for A and B. (1m)

A: _____ B: _____

b) Wind (moving air) can be useful and harmful. State one instance each of when it can be useful and when it can be harmful. (2 m)

Useful : _____

Harmful : _____

41. Katherine put three different types of animals X, Y and Z into two aquariums, A and B. She put Animals X and Z in Aquarium A and Animals X and Y in Aquarium B. She also put some water plants in both aquariums. She counted the number of animals in the aquariums weekly for a month. Her results are shown in the graphs below. No dead animals were visible in the aquariums during the weekly checks.

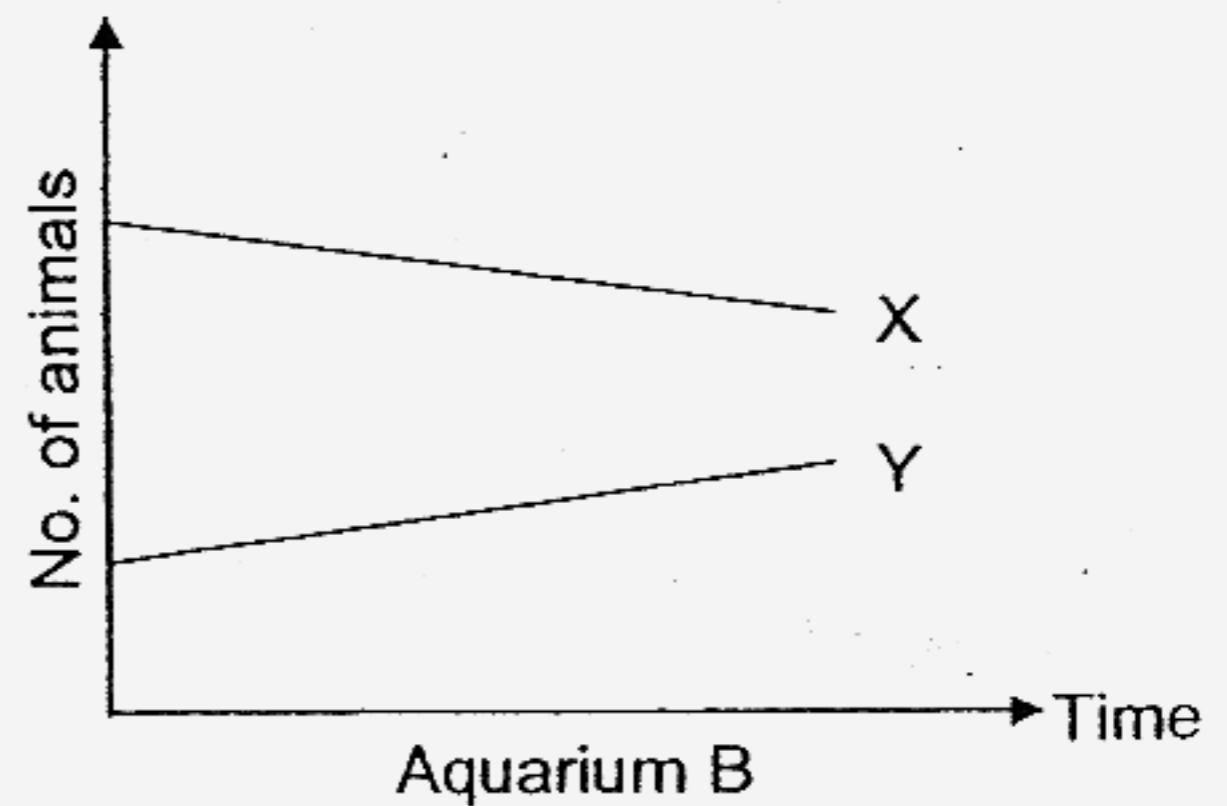
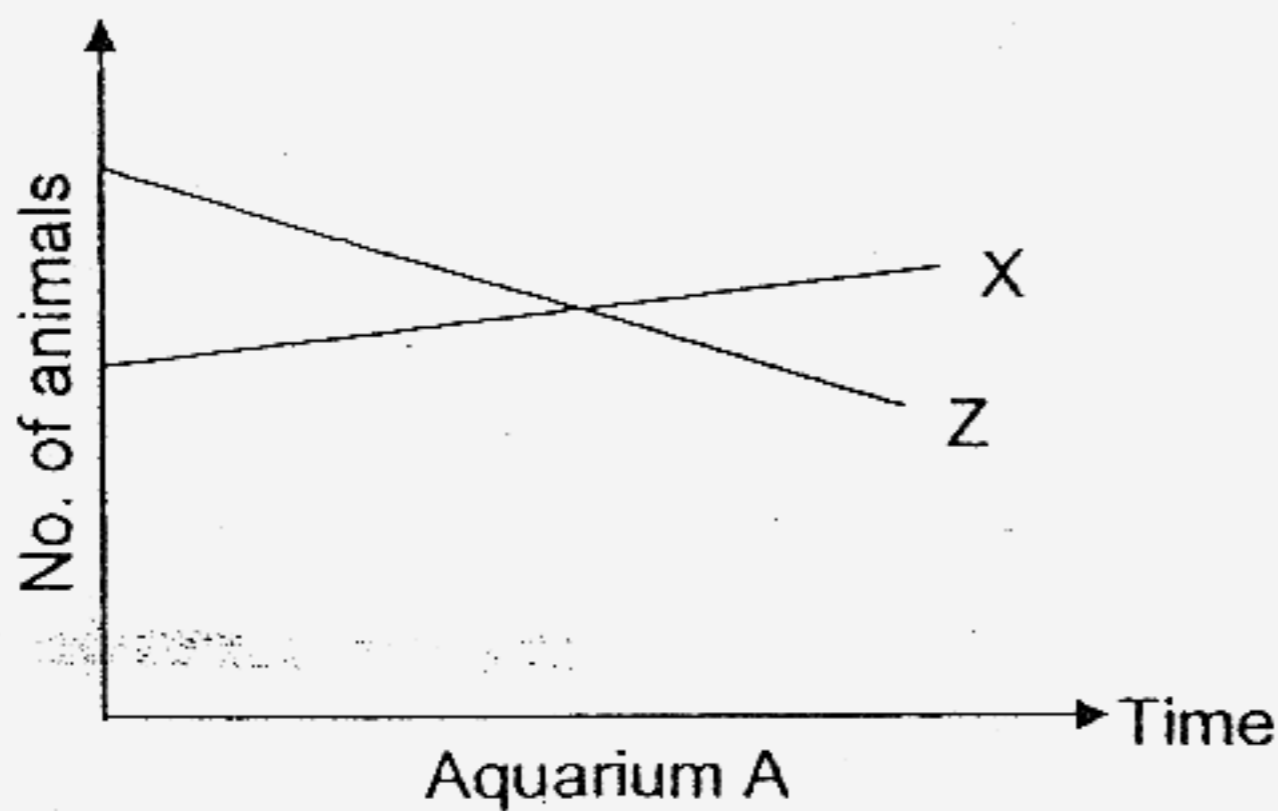

Complete the food chain linking these three animals. (2m)

Plant → _____

42. Jolyn set up the circuit shown below. The bulb will not light up. His friend told him that he had made a mistake.

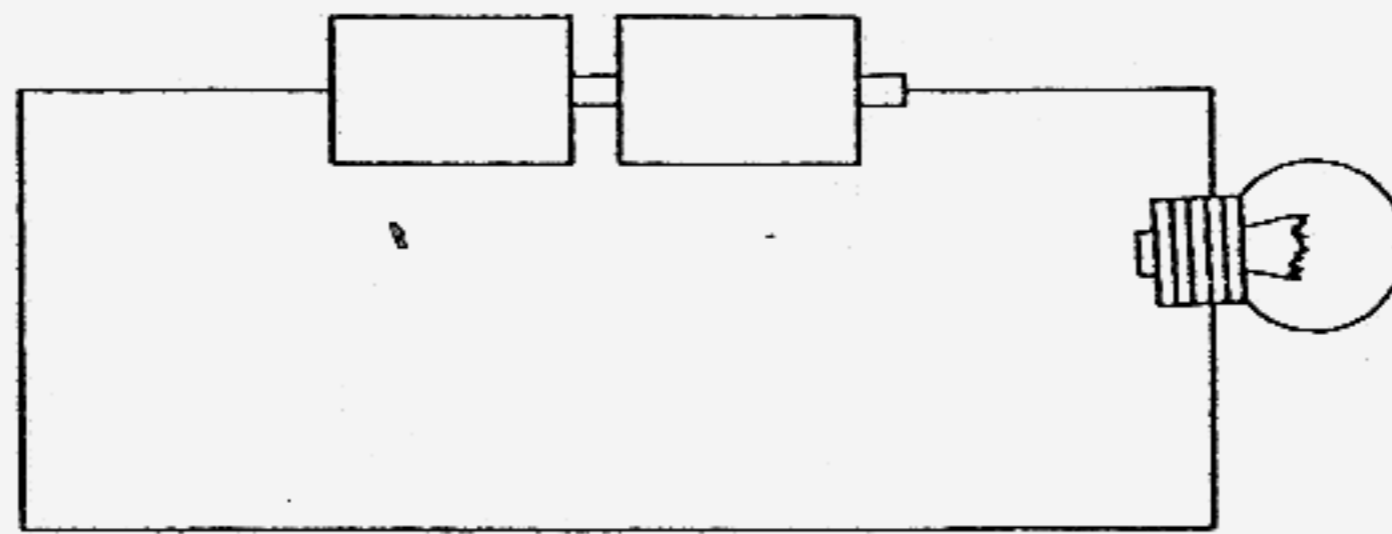

- a) What was the mistake made in the above set up? (1m)

- b) After correcting his mistake, the bulb still did not light up. State one possible reason for this. (1m)

43. Study the electrical circuits below carefully.

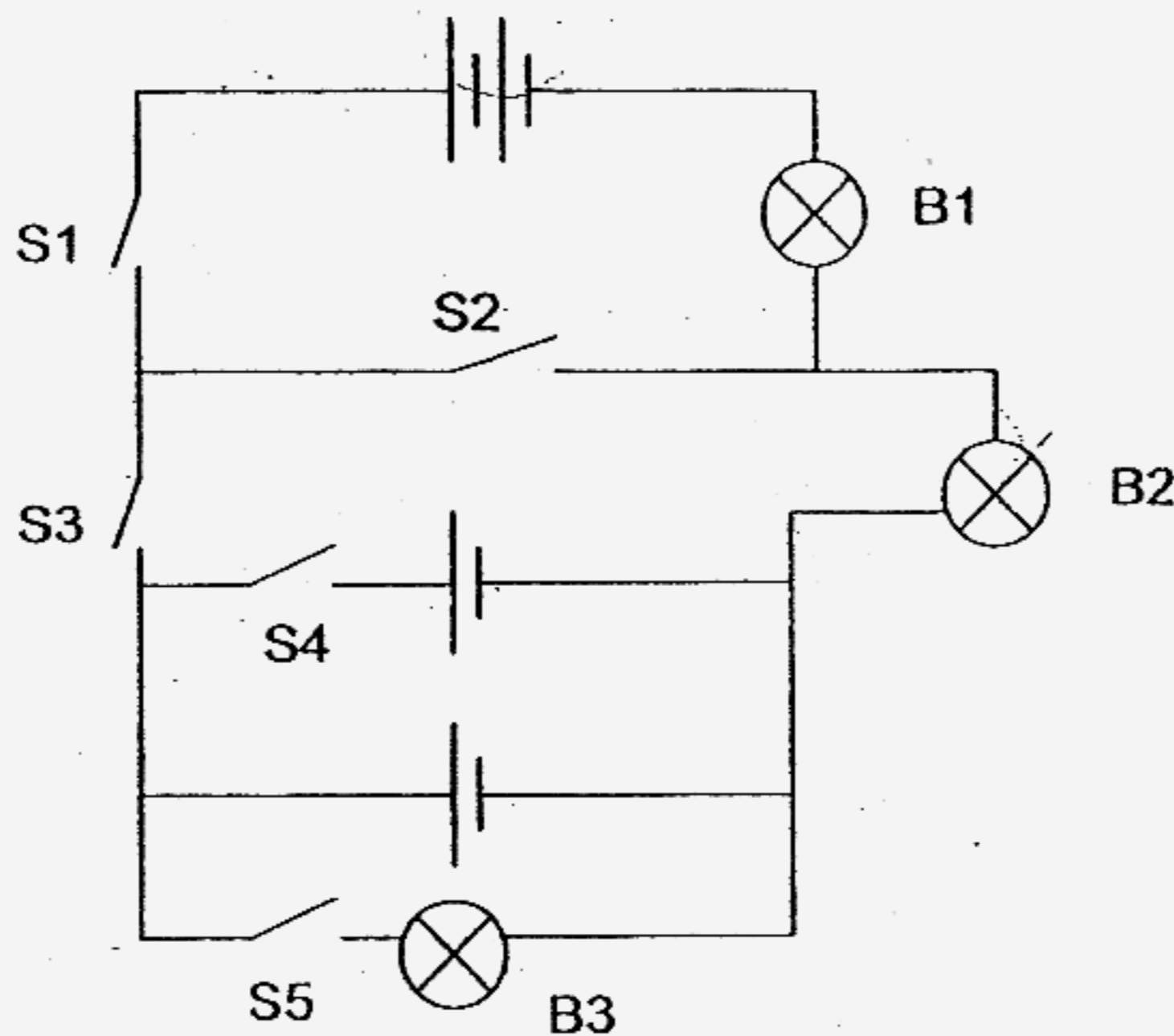

- a) How many switch(es) must be closed to light up only B1? (1m)

- b) What is the least number of switches that must be closed to light up all three bulbs? (1m)

- c) Explain why we avoid putting too many batteries in series arrangement. (1m)

44. Three sets of wheels and axles, A, B and C are shown below. The effort (E) in each case is just enough to lift the 20kg load.

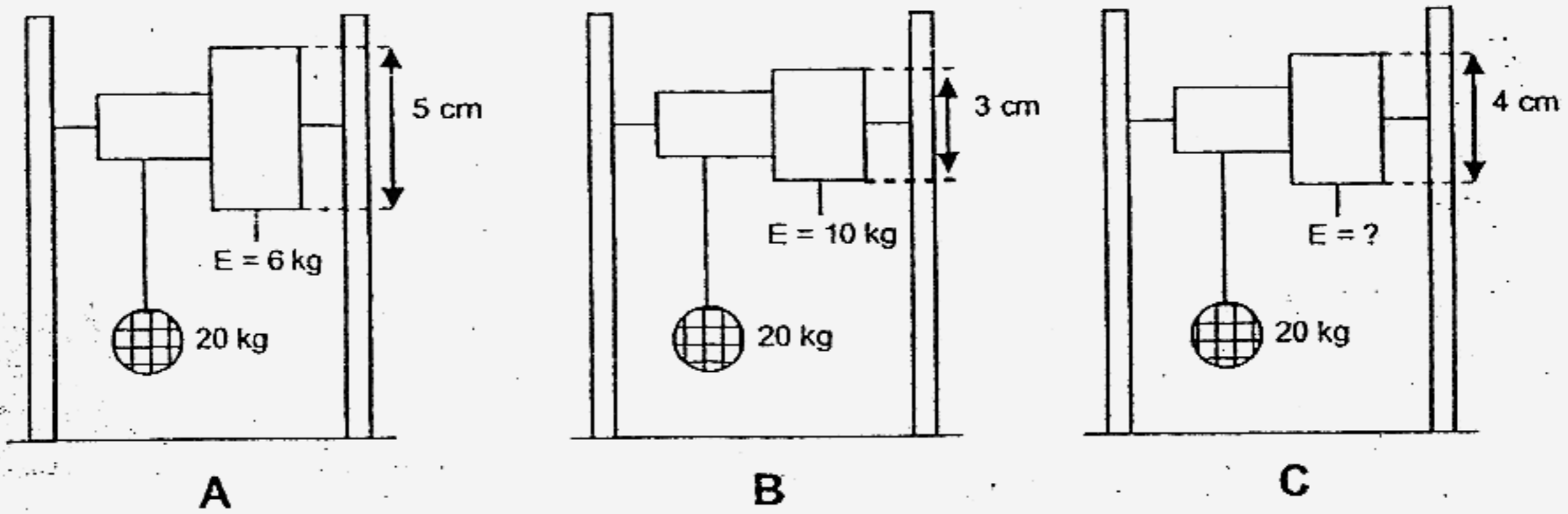

- a) What is the effort needed in C? (1m)
-
- b) State the relationship between the diameter of the wheel and the effort needed to lift the load. (1m)
-

45. The diagram below shows a system of gears. Study the diagram carefully and answer the following questions.

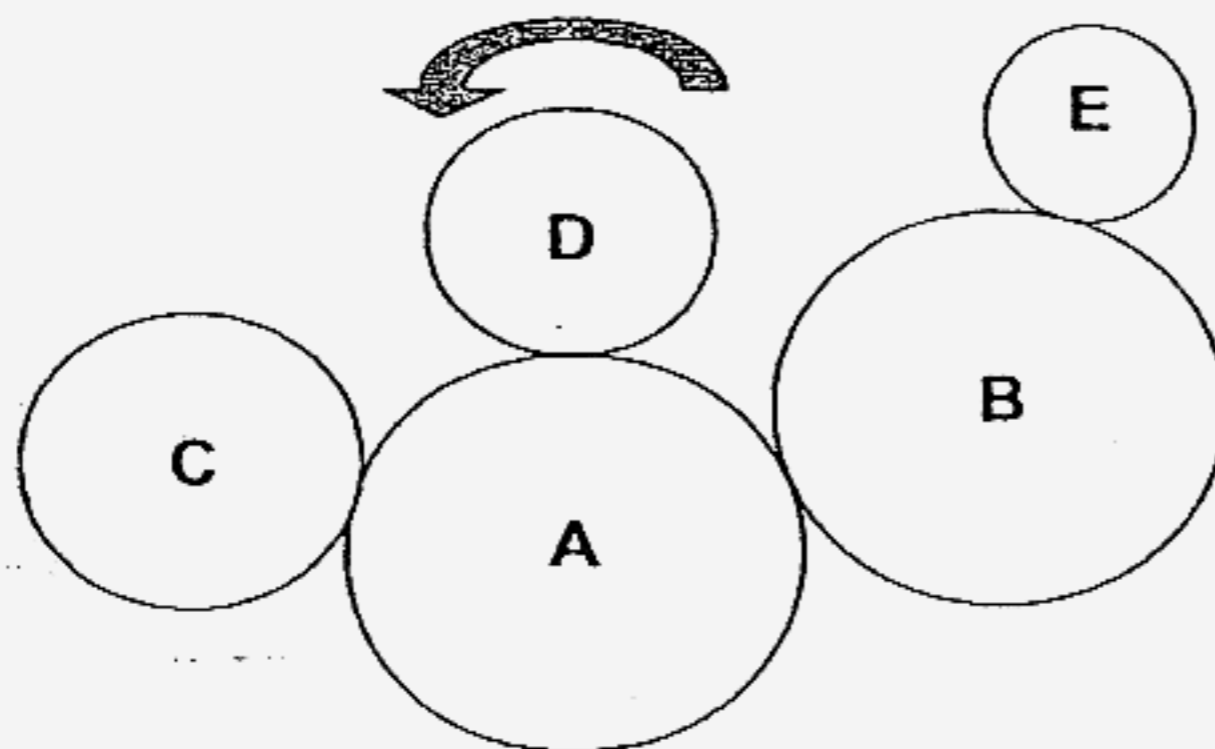

Legend:	
Gear A	– 45 teeth
Gear B	– 45 teeth
Gear C	– 30 teeth
Gear D	– 15 teeth
Gear E	– 10 teeth

- a) Which gears will turn clockwise if gear D turns anti-clockwise? (1m)
-
- b) Complete the table below to reflect the number of turns Gears C and E make when Gear A makes 3 complete turns. (2m)

	Gear A	Gear C	Gear E
Number of turns	3		

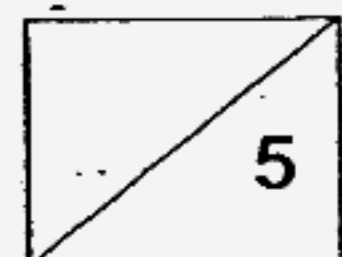

46. James was given a steel bar, two batteries, a long piece of wire and some paper clips (as shown below). He was told to make an electromagnet. However, he was not sure how to set it up.

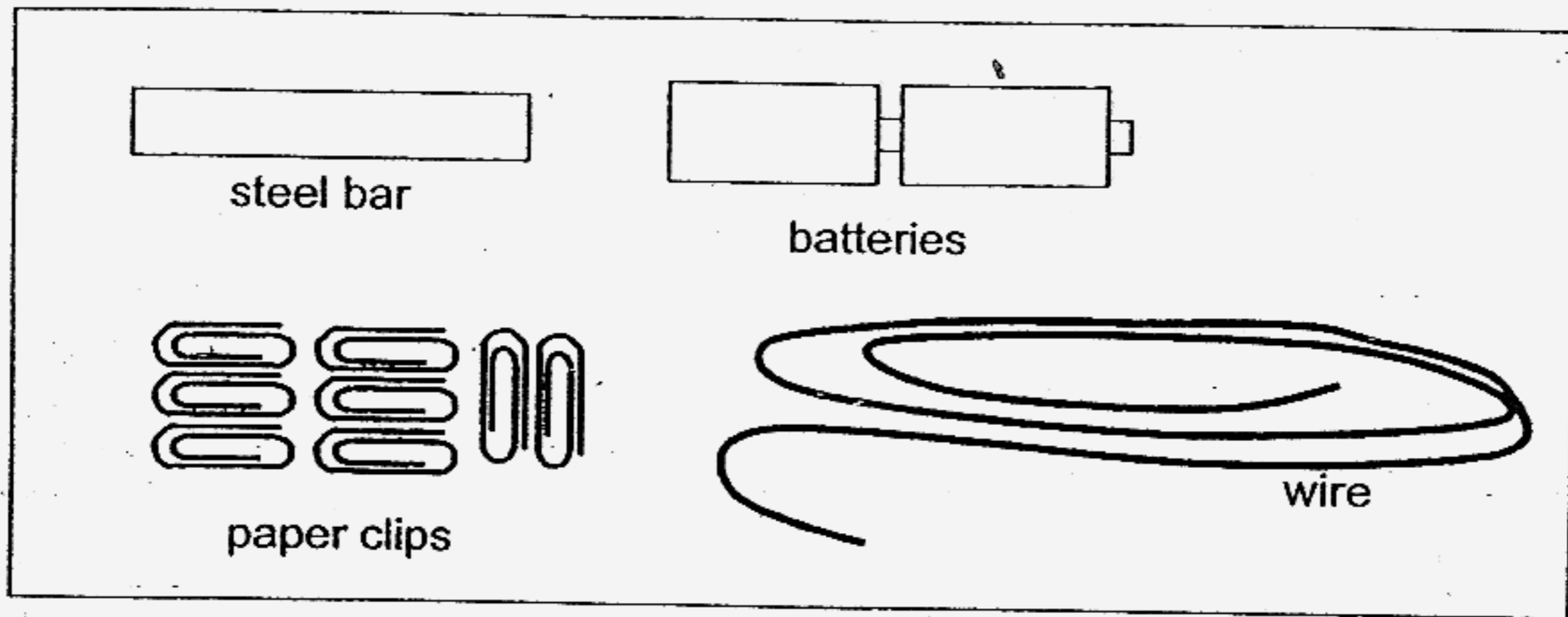

- a) Help James by drawing the set-up to make an electromagnet out of the steel bar in the space below. (2m)
You may use a pencil or a blue pen to draw the set-up.

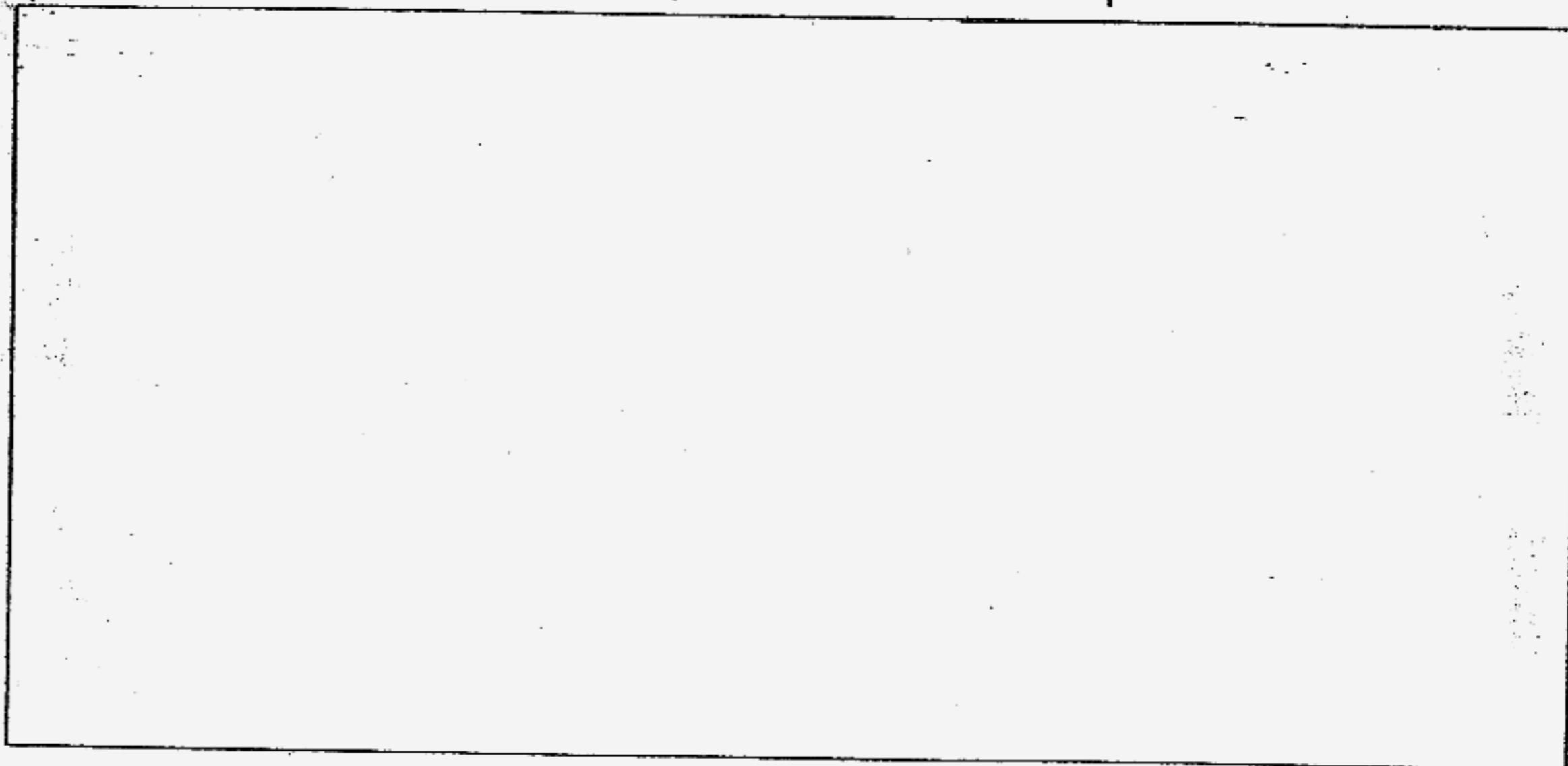

- b) List two ways in which James can make the electromagnet stronger. (2m)

- i) _____
ii) _____

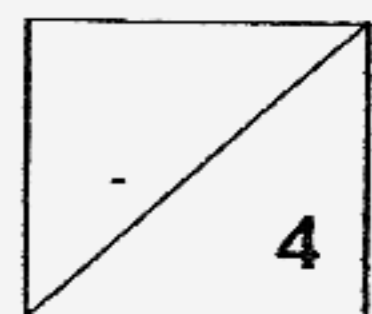

SCGS Primary School

Primary 5 Science SA2 Exams (2007)

Answer Keys

SECTION A : (60 MARKS)

Qn no.	Ans
1	4
2	3
3	4
4	3
5	2
6	3
7	3
8	2
9	4
10	2

Qn no.	Ans
11	4
12	1
13	4
14	2
15	3
16	1
17	4
18	3
19	1
20	3

Qn no.	Ans
21	4
22	4
23	2
24	1
25	4
26	3
27	4
28	2
29	1
30	2

SECTION B (40 MARKS)

31a Material X is durable, is a conductor of electricity, is not transparent and cannot float on water

31b Materials Y and Z. The toy boat must be durable and floats on water.

32a To find out if the area of the exposed surface affects the rate of evaporation.

32b Yes. Only 1 variable was changed.

33a ✓ ✓

33b Refrigerator

34a

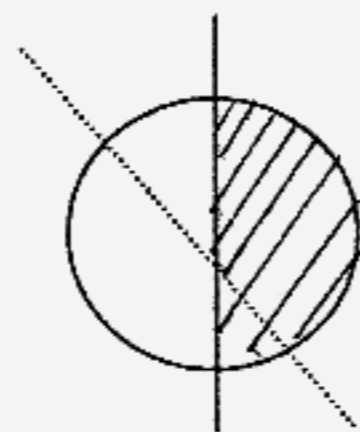

34b axis, west, east

35a



35b To make sure water droplets drop into the beaker.

35c Add another candle.

36a 20 years to 30 years
36b Cell division makes the cell multiply to replace the broken or dead cells

37a Dimples
37b Five people

38a Fern
38b Light and has hair

39a Plants take in more carbon dioxide than producing it.
39b Photosynthesis and respiration.

40a A: Push B: Pull
40b Useful : It can be used to dry clothes.
Harmful : It Tornado the fire.

41. Plant → Animal Z → Animal X → Animal Y.

42a One end of the wire has to be connected to the metal tip.
42b The bulb has fused.

43a 2 switches
43b 3 switches
43c It might blow the bulb.

44a 8kg
44b The shorter the diameter of the wheel, the more the effort is needed.

45a Gears A and E.

45b $4\frac{1}{2}$, $13\frac{1}{2}$

46a

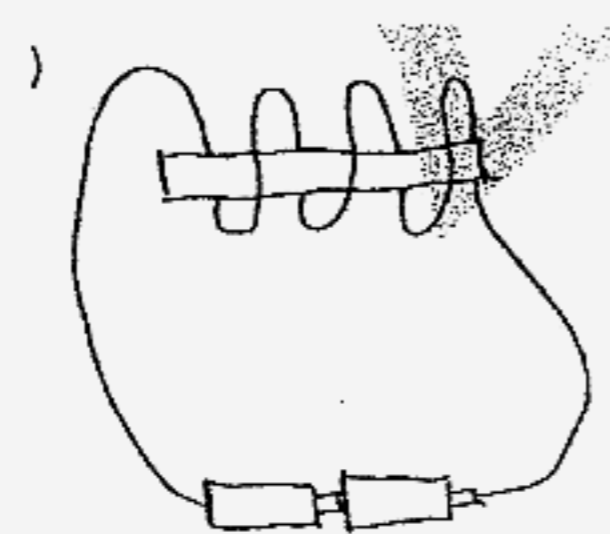

46b i) Increase the no. of coils round the steel bar.
46b ii) Increase the no. of batteries.